

ABB-Welcome

M2303 Guard Unit



ABB-Welcome

1	Safety	4
2	Intended use.....	4
3	Environment	4
3.1	ABB devices	4
4	Operation.....	6
4.1	Standard operation	6
4.1.1	Control elements	6
4.1.2	Welcome screen and status bar	8
4.2	Control actions.....	10
4.2.1	Incoming call / During a call	10
4.2.2	Display settings during calls	12
4.2.3	Intercept mode.....	13
4.2.3.1	VIP settings	15
4.2.4	Communication.....	18
4.2.5	Surveillance	21
4.2.6	Switch actuator	22
4.2.7	User list.....	23
4.2.8	History	25
4.2.9	Settings (Basic)	28
4.2.9.1	Ringtone settings.....	28
4.2.9.2	Volume settings	29
4.2.9.3	Date and time settings.....	30
4.2.9.4	Other settings	31
4.2.9.5	Language settings	32
4.2.9.6	Information.....	33
4.2.10	Settings (Advanced)	34
4.2.10.1	Switch actuator settings.....	35
4.2.10.2	Program button settings.....	37
4.2.10.3	User list management.....	38
4.2.10.4	Call code settings	42
4.2.10.5	Password settings	43
4.2.10.6	Reset factory default.....	44
4.2.10.7	Reset Password & Clear All Data	45
4.3	Cleaning	46
4.4	Adjusting the device.....	47
5	Technical data	48

ABB-Welcome

6	Mounting / Installation.....	49
6.1	Requirements for the electrician	49
6.2	General installation instructions	50
6.3	Mounting.....	51

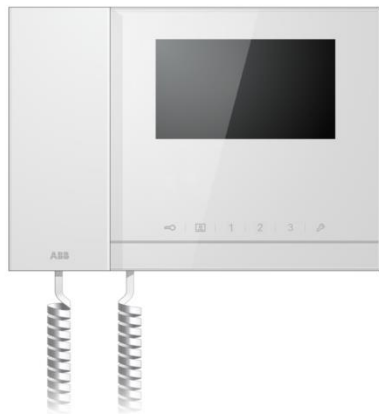
1 Safety



Warning

Electric voltage!

Risk of death and fire due to electrical voltage of 100-240 V.

- Work on the 100-240V supply system may only be performed by authorised electricians!
- Disconnect the mains power supply prior to installation and/or disassembly!

2 Intended use

The M2303 is an integral part of the ABB-Welcome door communication system and operates exclusively with components from this system. The device must only be installed in dry indoor rooms.

3 Environment



Consider the protection of the environment!

Used electric and electronic devices must not be disposed of with domestic waste.

- The device contains valuable raw materials which can be recycled. Therefore, dispose of the device at the appropriate collecting depot.

3.1 ABB devices

All packaging materials and devices from ABB bear the markings and test seals for proper disposal. Always dispose of the packaging material and electric devices and their components via the authorized collecting depots and disposal companies.

ABB-Welcome

ABB products meet the legal requirements, in particular the laws governing electronic and electrical devices and the REACH ordinance.

(EU-Directive 2002/96/EG WEEE and 2002/95/EG RoHS)

(EU-REACH ordinance and law for the implementation of the ordinance (EG)

No.1907/2006)

4 Operation

4.1 Standard operation

4.1.1 Control elements

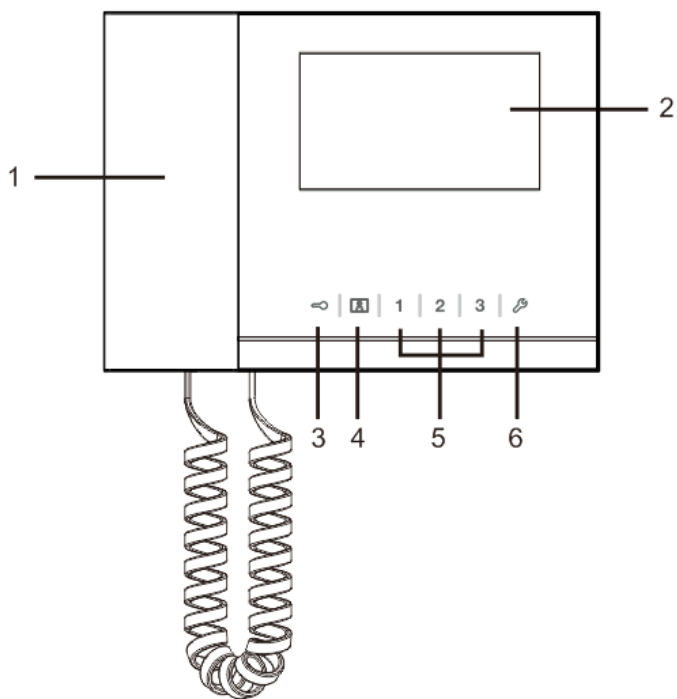

Fig. 1 Over view of the control buttons

ABB-Welcome

No.	Function
1	Handset When a call is coming, pick up handset to activate the communication within 30 seconds and hang up handset to end the call.
2	4.3" Touch screen.
3	Unlock button Press this button to open the door at any time. If the LED flashes slowly, this means an incoming call. If the LED flashes rapidly, it means system is busy or the door has been opened over the set time (The sensor must be connected first).
4	Surveillance button In standby mode, press this button to survey the default outdoor station.
5	Programmable button 1,2,3 5A *Programmable buttons for additional functions, e.g. control the switch actuator. 5B Default function of button 1 is release the lock connected with an outdoor station (COM-NC-NO)
6	System setting button Enter into the system setting for various functions of the device.

*For their use, please contact your electrical installer.

4.1.2 Welcome screen and status bar

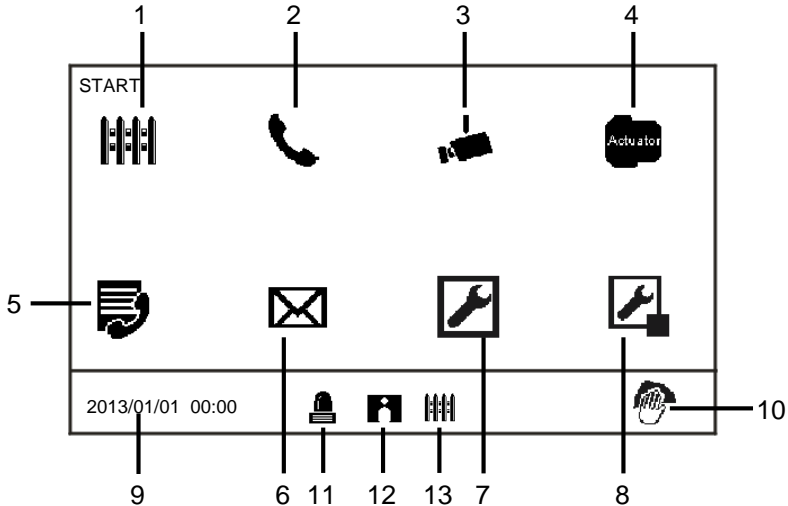

Fig. 2 Start

On the start page, the following functions are available:

No.	Function
1	Intercept - Press this button to switch to intercept settings.
2	Communication - Press this button to enter the communication menu
3	Surveillance In standby mode, press this button to survey the default outdoor station.
4	Switch actuator - Press this button to enter the switch actuator menu and enable the existing actuators here.
5	User list - Touch this button and then check the contact list.
6	History - Press this button to enter the history menu. All events and alarms from indoor stations can be found here.
7	System settings (basic) - Press this button to set some basic functions for the device, e.g. ringtone, volume and local language.

ABB-Welcome

8	System settings (advance) - Press this button to set the various advanced functions for the device, e.g. switch actuator setting and user list management.
9	Date and time - Press this button to switch to date and time settings.
10	Cleaning locking - This icon appears when the display is locked to prevent functions being triggered during cleaning.
11	Alarm history - This icon appears when new alarm information is available in the alarm history. - Touch this icon and then events will be displayed.
12	Call history - The icon appears when new call information is available in the call history. - Touch this icon and then events will be displayed.
13	Intercept - The icon appears when the guard unit is in the intercept mode.

4.2 Control actions

4.2.1 Incoming call / During a call

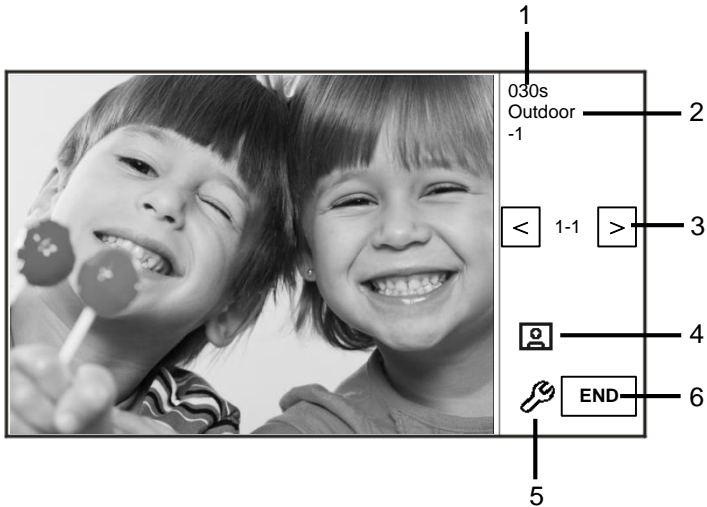

Fig. 3 Incoming call from Outdoor station

When Outdoor station calling, the following functions are available:

No.	Function
1	Time left of the connection.
2	Number of outdoor stations.
3	Surveillance Press this button to surveil the analog camera of the outdoor station if there is one.
4	Snapshot - Press this button to take a snapshot.
5	Display settings - Press this button to enter the display settings.
6	End the connection.

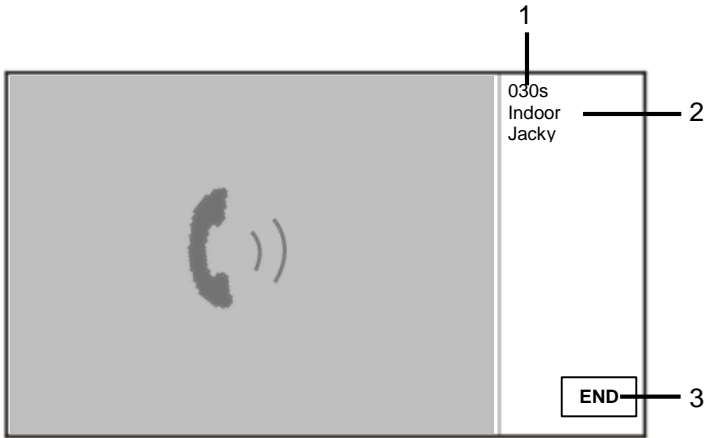

Fig. 5 Incoming call from Indoor station

When Indoor station calling, the following functions are available:

No.	Function
1	Time left of the connection.
2	User name If associate the Physical address of the indoor station with a user name in USER LIST MANAGEMENT. Here will display the user name not Physical address or Logical address.
3	End the connection.

4.2.2 Display settings during calls

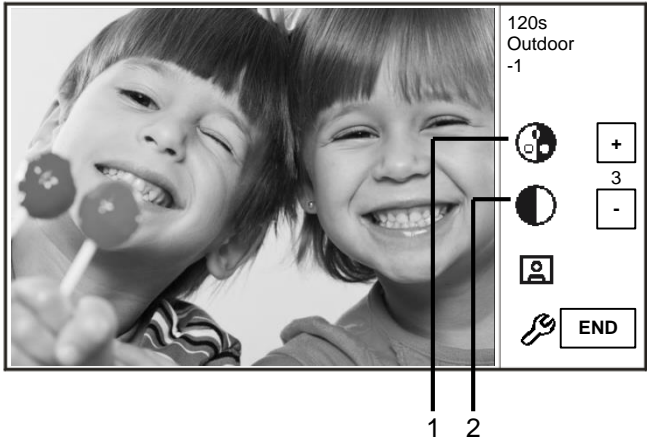



Fig. 6 Display settings during calls

The following functions are available if you press  button.

No.	Functions
1	Adjust the saturation of the display through the "Plus / Minus" buttons.
2	Adjust the brightness of the display through the "Plus / Minus" buttons.

4.2.3 Intercept mode

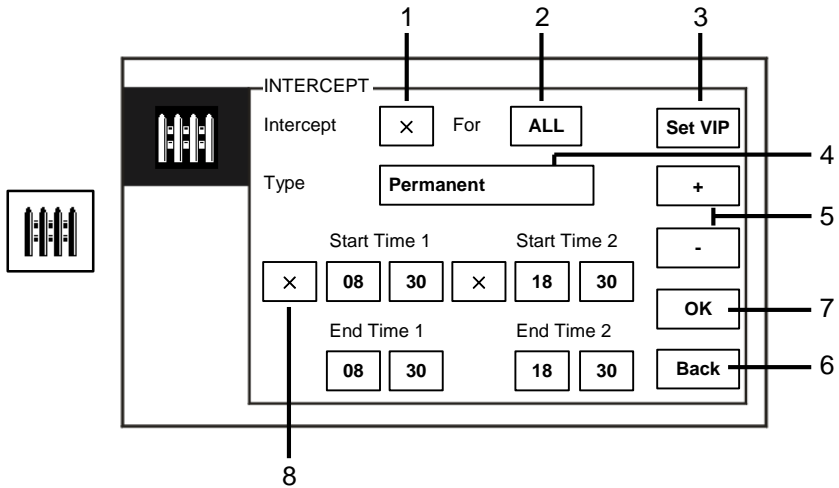

Fig. 7 Intercept mode

In the “Intercept”, the following functions are available:

No.	Function
1	Activate or deactivate the intercept function by ticking the checkbox
2	Activate the intercept function to intercept calls for all users or for VIPs only by ticking the checkbox - “all” means that the guard unit will intercept calls for all users.. - “VIP” means that the guard unit will intercept calls for VIPs only
3	Set VIPs (available only when there are VIPs) - Press this button to set the VIPs.
4	Choose the type of intercept by ticking the checkbox - “Permanent” mode and “Repeat” mode are available.
5	“Plus / Minus” buttons.
6	Back - Press this button to return to the start page without saving the settings.
7	OK - Press this button to save the settings.
8	In the “Repeat” mode, the timer(s) must be activated by ticking the checkbox.

ABB-Welcome

- | | |
|--|--|
| | <ul style="list-style-type: none">- When the timer is activated, set the start time and end time via the “Plus / Minus” buttons.- Before adjusting to the “Hour” or “Minute”., the active range is highlighted in blue- End time > Start time |
|--|--|

The function can only be set through master guard unit.

4.2.3.1 VIP settings

Press **Set VIP** to set the VIPs. A total of 64 entries can be added.

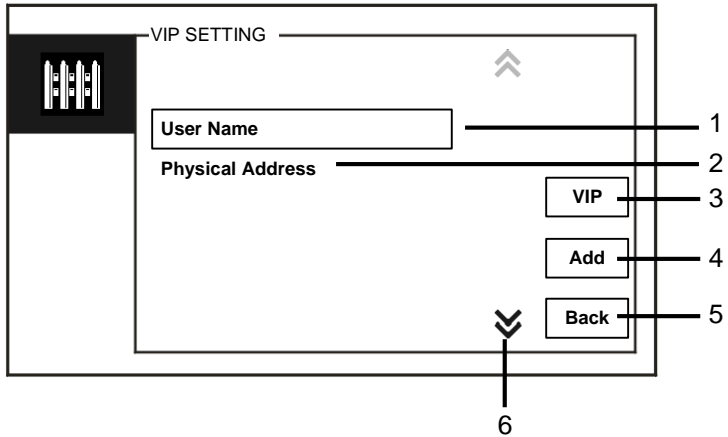

Fig. 8 VIP settings

The following functions are available:

No.	Functions
1	Select "User Name", press "Add" button, and then you can add new VIPs by user name (from the contact lists).
2	Select "Physical Address", press "Add" button, and then you can add new VIPs by their physical address.
3	"VIP" - Press the "VIP" button to check the VIP list .
4	"Add" - Press the "Add" button to add new VIPs.
5	"Back" - Press the "Back" button to return to the "Intercept" page.
6	"Scroll" - Switch to other settings by ticking the scroll box.

Press **VIP** to set VIPs.

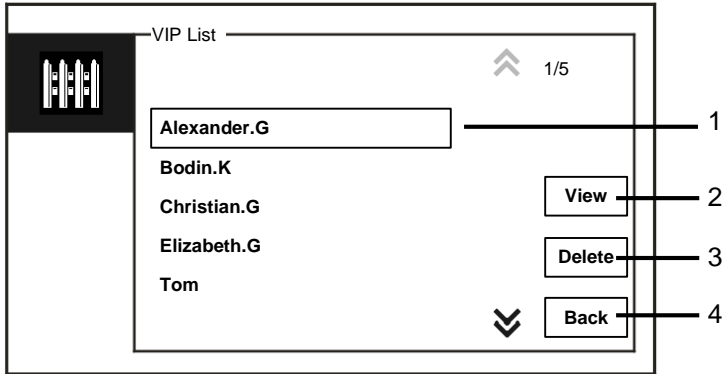

Fig. 9 VIP list

The "VIP list" menu has the following functions:

No.	Functions
1	VIP list - Displays all VIPs.
2	"View" - Press this button to display specific information of the selected VIP.
3	"Delete" - Press this button twice to delete the selected VIP.
4	"Back" - Press this button to return to the VIP settings menu.

ABB-Welcome

Select "Physical address" and press the "Add" button to enter "Add" menu.

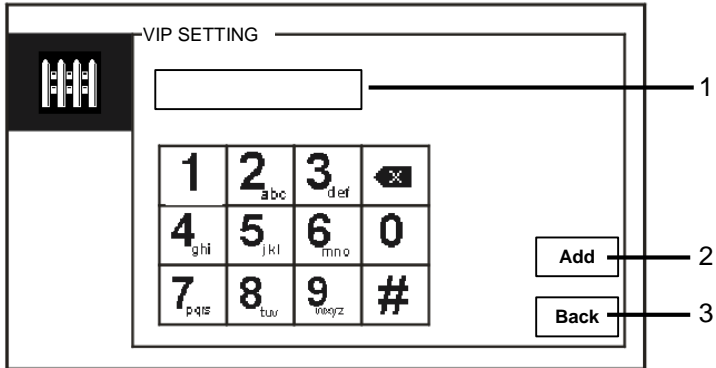

Fig. 10 Add VIPs by physical address

No.	Functions
1	Enter a physical address with the numeric keypad.
2	"Add" - Press this button to add a new VIP. Enter the correct physical address before pressing this button.
3	"Back" - Press this button to return to the VIP settings menu.

4.2.4 Communication

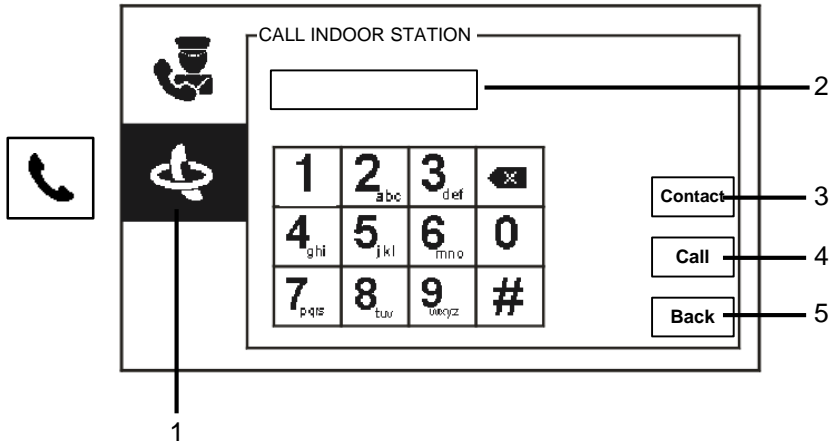

Fig. 11 Call indoor station

The “call indoor station” menu has the following functions:

No.	Functions
1	Click on the “Call indoor station”.
2	Enter a physical address or logic address to make a call to an indoor station. (select physical address or logic address from the call settings)
3	“Contact” Press “Contact” button to display the contact list, and make a call directly by user name.
4	“Call” - Press this button to make a call after you enter the number.
5	“Back” - Press this button to return to the start page.

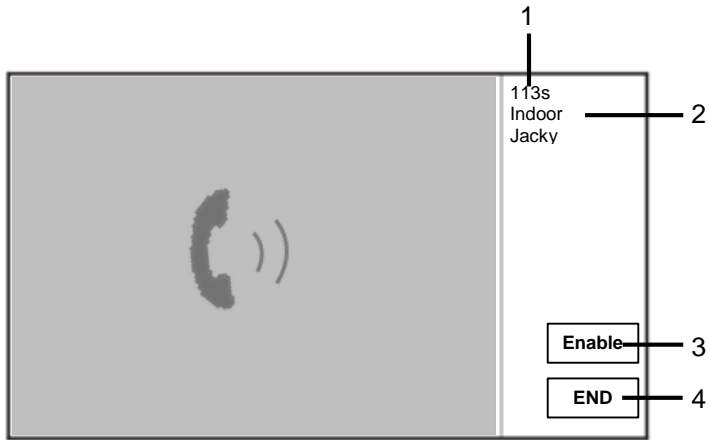

Fig. 12 Call to Indoor station

When GU call to Indoor station, the following functions are available:

No.	Function
1	Time left of the connection.
2	User name If associate the Physical address of the indoor station with a user name in USER LIST MANAGEMENT. Here will display the user name not Physical address or Logical address.
3	If Indoor station answers the call, Guard unit will display “enable”, when press “Enable”, Guard unit will send the image from associated Camera interface to indoor station and Guard unit itself.
4	End the connection.

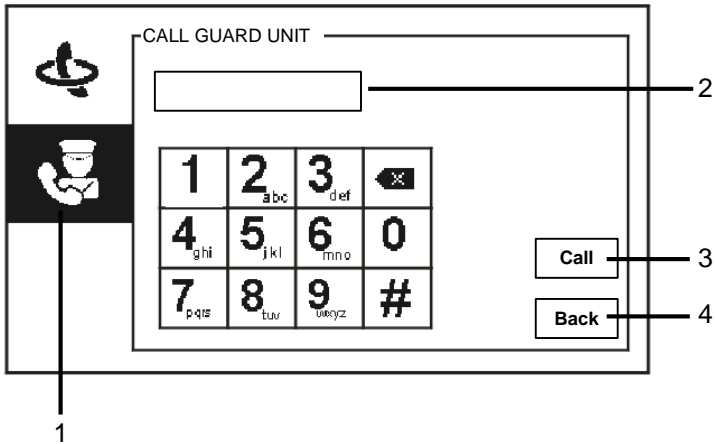

Fig. 13 Call guard unit

The "Call guard unit" menu has the following functions:

No.	Functions
1	Click on the "Call guard unit."
2	Enter a guard unit address. If the called guard unit is in the same building, press number 1~9 to make a call. If the called guard unit is not in the same building, press the building number + guard unit address to make a call, e.g. building No.(1~60)+guard unit address (1~9).
3	"Call" - Press this button to make a call after you enter the number.
4	"Back" - Press this button to return to the start page.

4.2.5 Surveillance



Fig. 14 Surveillance

Press  button to survey the default outdoor station. The following functions are available:

No.	Functions
1	Press this button to survey the next outdoor station.
2	Use the handset to establish an audio connection with the current outdoor station under connection.

4.2.6 Switch actuator

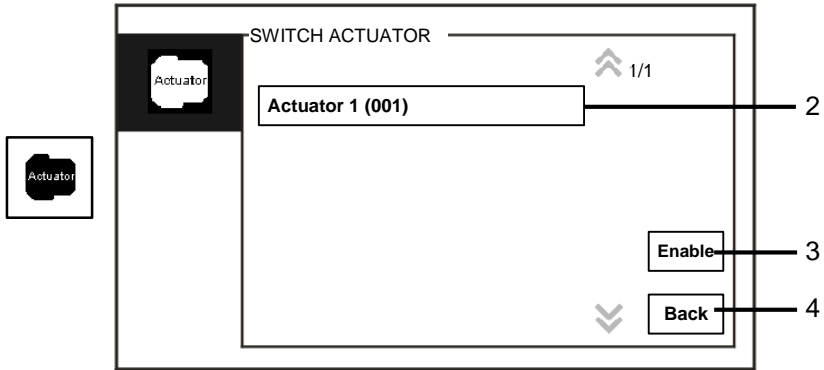

Fig. 15 Switch actuator

The "Switch actuator", menu has the following function:

No.	Functions
1	Actuator list - Establish an actuator list by clicking on "system settings (advance) - switch actuator" in turn.
2	"Enable" - Press this button to activate the selected actuator.
3	"Back" - Press this button to return to the start page.

4.2.7 User list

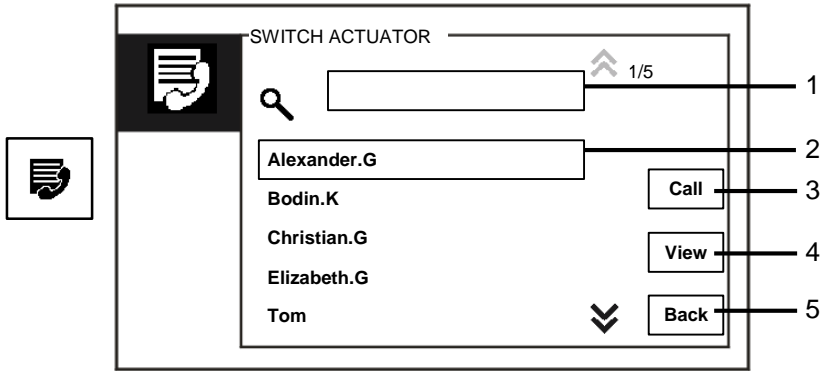

Fig. 16 User list

The “Contact” menu has the following functions:

No.	Functions
1	“Search box” - Search a user name by entering a few letters of the first name.
2	“Contact list” - Lists contacts.
3	“Call” - Press this button to call the selected contact..
4	“View” - Show specific information of the selected contact.
5	“Back” - Press this button to return to the start page.

Press the "View" button to show specific information from the contact list.

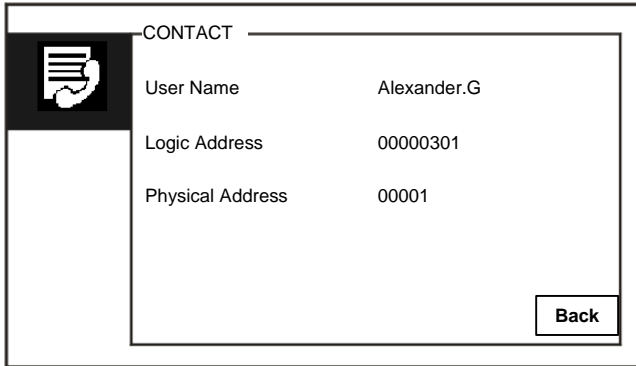

Fig. 17 Specific information in the contact list

4.2.8 History

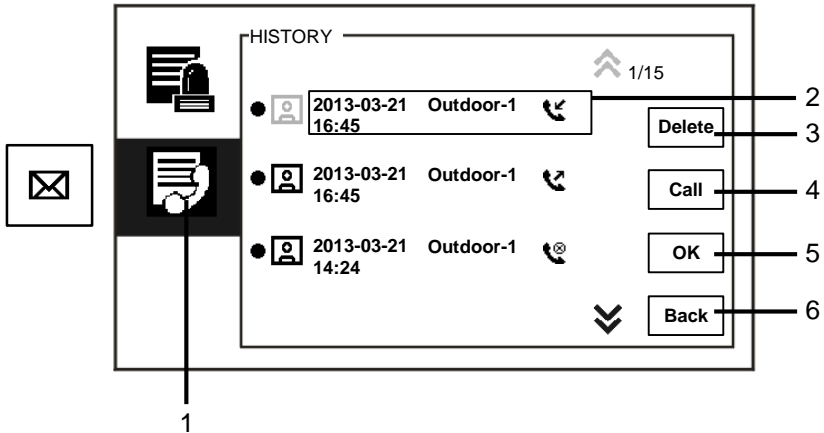

Fig. 18 History

The “History” menu has the following functions:



No.	Functions
1	Click on “History”.
2	<p>Up to 100 events can be recorded in the “history menu”.</p> <ul style="list-style-type: none"> - If there is a snapshot function that is active, a icon is enabled. If In case there is no snapshot function, this icon is disabled. - Date, time and event type are recorded together with the snapshot. - Directions: <ul style="list-style-type: none">  means dialing calls  means receiving calls  means missing calls
3	<p>“Delete”</p> <ul style="list-style-type: none"> - Press this button to delete the selected call from the history.
4	<p>“Call”</p> <ul style="list-style-type: none"> - Press this button to call back the selected call from the indoor station.
5	<p>“OK”</p> <ul style="list-style-type: none"> - Press this button to view the specific information.
6	<p>“Back”</p> <ul style="list-style-type: none"> - Press this button to return to the start page.

ABB-Welcome

Press the “OK” button to view specific information.

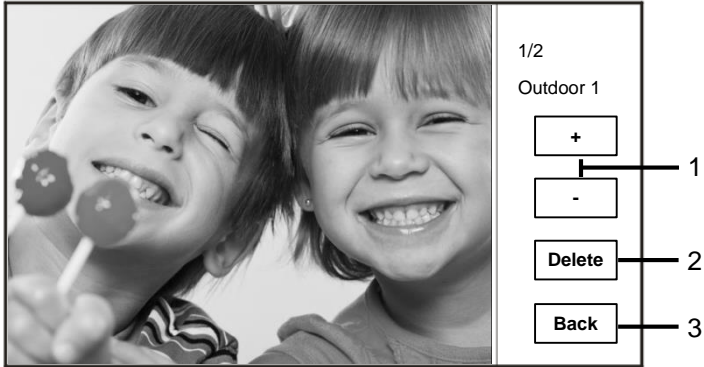

Fig. 19 Specific history information

No.	Functions
1	Press the “Plus / Minus” button to view the previous or the next photo.
2	“Delete” - Press this button twice to delete the photo.
3	“Back” - Press this button to return to the “History” menu.

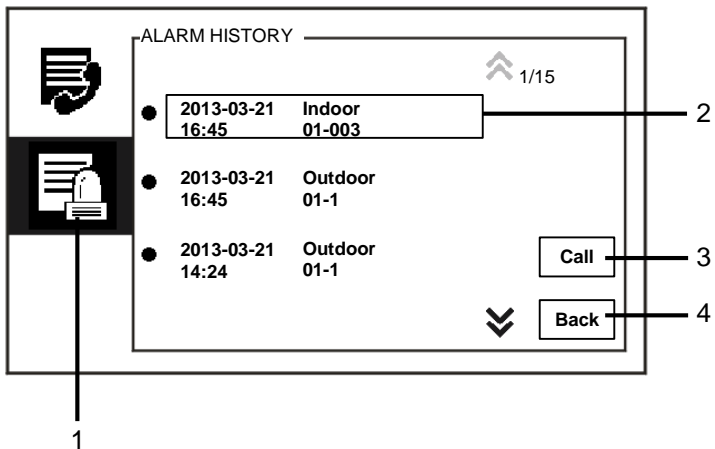

Fig. 20 Alarm history

The "Alarm History" menu has the following functions:

No.	Functions
1	Click on "Alarm History".
2	Up to 500 alarms can be recorded in the "Alarm History" menu. - Date and time of an alarm are recorded together with the event.
3	"Call" - Press this button to call back the selected call from the history
4	"Back" - Press this button to return to the start page.

4.2.9 Settings (Basic)

4.2.9.1 Ringtone settings

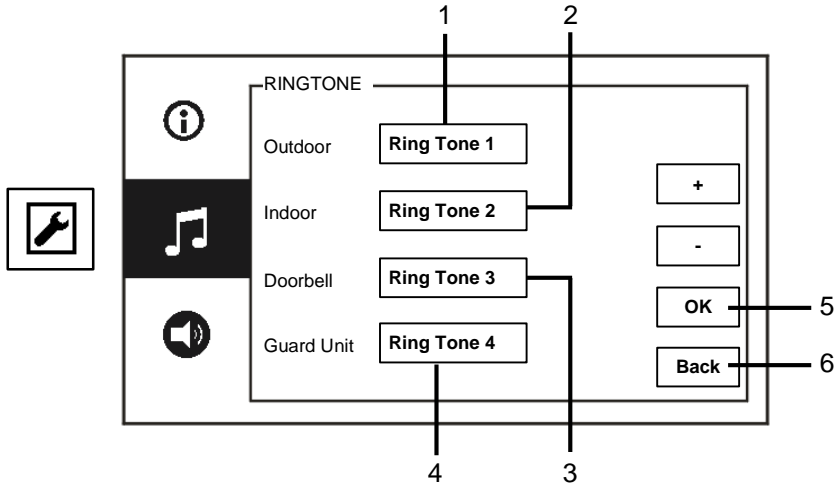

Fig. 21 Ringtone settings

The “Ringtone” menu has the following functions:

No.	Functions
1	Press the “Plus / Minus” button to select a bell sound for calls from outdoor stations.
2	Press the “Plus / Minus” button to select a bell sound for calls from indoor stations.
3	Press the “Plus / Minus” button to select a bell sound like an apartment door bell ..
4	Press the “Plus / Minus” button to select a bell sound for calls coming from other guard units
5	“OK” - Press this button to save the settings.
6	“Back” - Press this button to return to the start page.

4.2.9.2 Volume settings

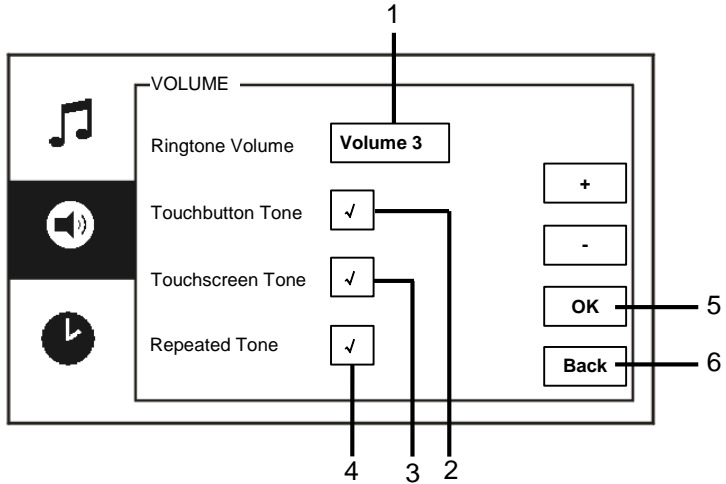

Fig. 22 Volume settings

The “Volume” menu has the following functions:

No.	Functions
1	“Ringtone volume” - Press the “Plus / Minus” button to set the volume of the bell sound.
2	“Touch button tone” - Enable/disable the feedback tone which sounds when the touch button is pressed.
3	“Touch screen tone” - Enable/disable the feedback tone which sounds when the touch screen is pressed.
4	The ringtone can be set fixed or cycled.
5	“OK” - Press this button to save the settings.
6	“Back” - Press this button to return to the start page

4.2.9.3 Date and time settings

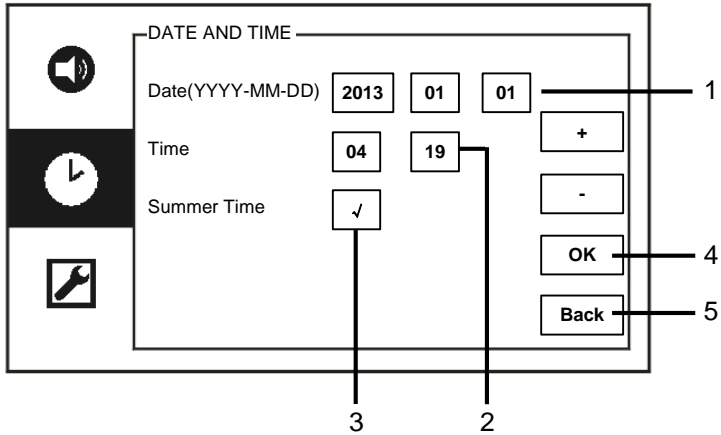

Fig. 23 Date and time settings

The “Date and time” menu has the following functions:

No.	Functions
1	“Date” - Press the “Plus / Minus” button to set date.
2	“Time” - Press the “Plus / Minus” button to set time .
3	“Summertime” - Enable/disable the summertime by ticking the checkbox.
4	“OK” - Press this button to save the settings.
5	“Back” - Press this button to return to the start page.

4.2.9.4 Other settings

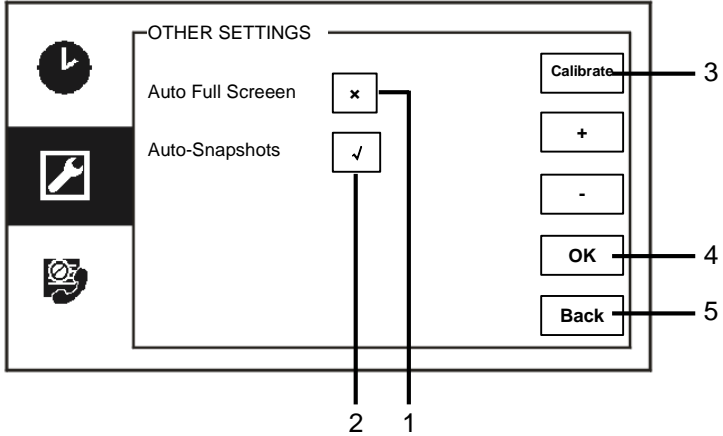

Fig. 24 Other settings

The “Other settings” menu has the following functions:

No.	Functions
1	“Auto full screen” - Enable/disable the auto full screen function by ticking the checkbox or pressing the “Plus / Minus” buttons.
2	“Auto snapshots” - Enable/disable the auto-snapshots function by ticking the checkbox (automatic switchover) or pressing the “Plus / Minus” buttons.
3	“Calibrate” - If the buttons and the associated graphics on the display are no longer superimposed, the monitor must be calibrated. - Press the “calibrate” button and then confirm that the dialogue box is displayed. Tick the 5 displayed position dots consecutively. Finally, confirm that the dialogue box displayed. Then, the calibration of the display is finished.
4	“OK” - Press this button to save the settings.
5	“Back” - Press this button to return to the start page.

4.2.9.5 Language settings

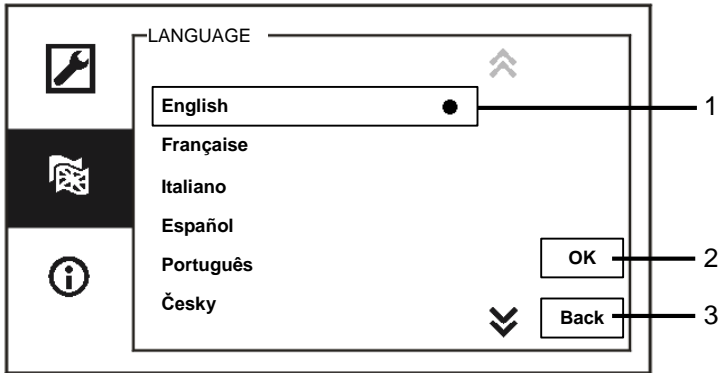

Fig. 25 Language settings

The “Language” menu has the following functions:

No.	Functions
1	Languages (list box) <ul style="list-style-type: none">- Here, the available languages are listed.- The current language is marked with a dot.
2	“OK” <ul style="list-style-type: none">- Press this button to save the settings.
3	“Back” <ul style="list-style-type: none">- Press this button to return to the start page.

4.2.9.6 Information

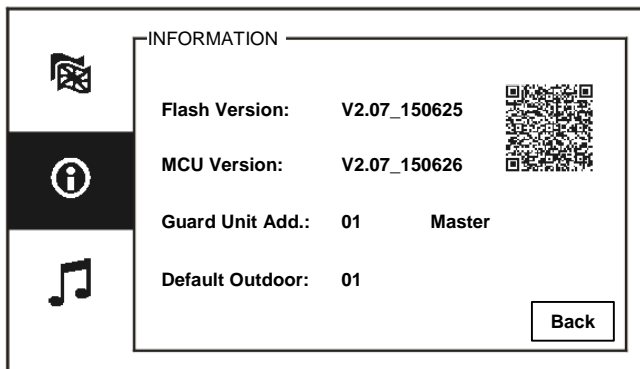

Fig. 26 System information

Display the current version and the address of this guard unit (scanning the QR code to get the specific instructions for this guard unit)

4.2.10 Settings (Advanced)

Enter the system password to access the advance settings.
The default password is 345678.

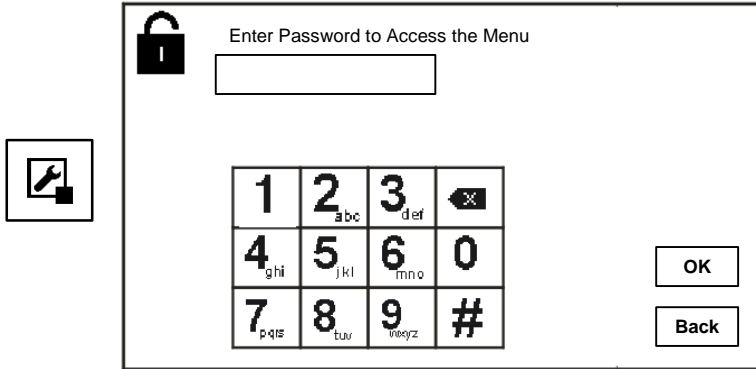

Fig. 27 Password

4.2.10.1 Switch actuator settings

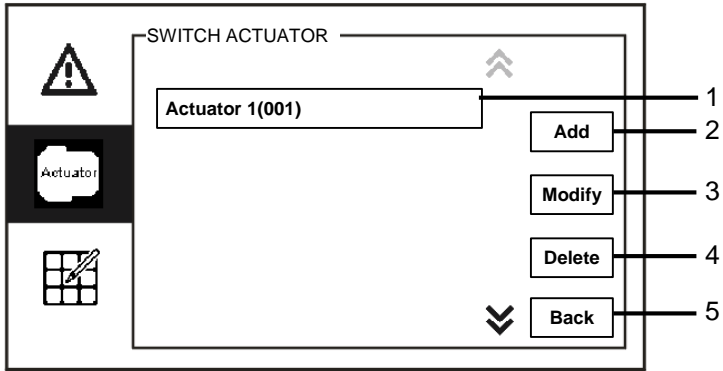

Fig. 28 Switch actuator settings

The “Switch actuator” menu has the following functions:

No.	Functions
1	Actuator (list box) - Here, the available actuators are listed.
2	“Add” - Press this button to add a new actuator. A total of up to 10 switch actuators can be added.
3	“Modify” - Press this button to modify existing actuator entries.
4	“Delete” - Press this button twice to delete an actuator.
5	“Back” - Press this button to return to the start page.

Press the “Add” button to add a new actuator

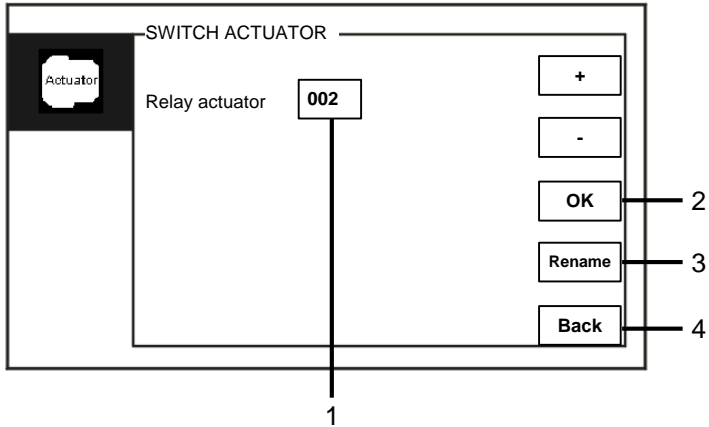

Fig. 29 Switch actuator settings

The “Add” button has the following functions:

No.	Functions
1	To add a new actuator list - Change the target address by scrolling up from 001 to 199 with the “Plus / Minus” buttons
2	“OK” - Press this button to save the settings.
3	“Rename” - Press this button to rename the actuator.
4	“Back” - Press this button to return to the start page.

4.2.10.2 Program button settings

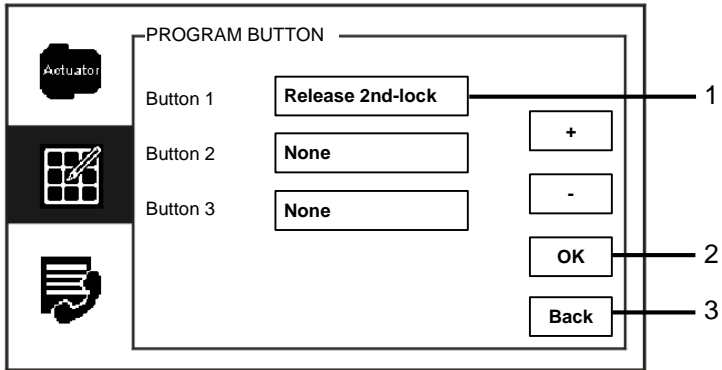

Fig. 30 Program button settings

The "Program button" has the following functions:

No.	Functions
1	Button 1 <ul style="list-style-type: none"> - Set the program function button by using the "Plus / Minus" buttons. - Functions such as. "release 2nd-lock" and "enable switch actuator" are available - "2nd-lock" means that the lock is connected with an outdoor station (NC-NO-COM) - Only the existing switch actuator list can be available with the program button.
2	"OK" <ul style="list-style-type: none"> - Press this button to save the settings.
3	"Back" <ul style="list-style-type: none"> - Press this button to return to the start page.

4.2.10.3 User list management

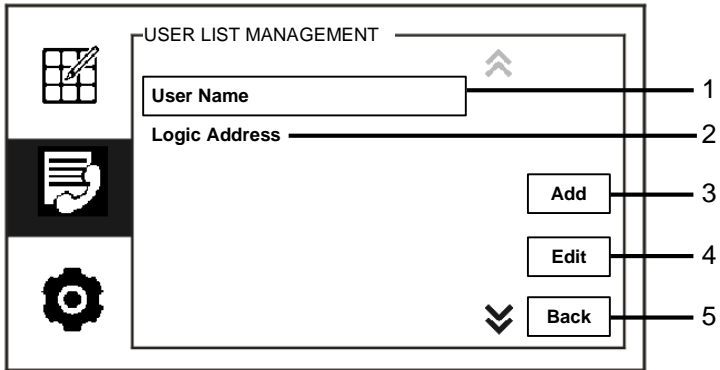

Fig. 31 User list management

The “Program button” menu has the following functions:

No.	Functions
1	“User name” - Add a contact list by user name.
2	“Logic address” - Add a contact list by logic address, e.g. your apartment No. 0101.
3	“Add” - Press this button to add a new contact list.
4	“Edit” - Press this button to edit an existing contact list.
5	“Back” - Press this button to return to the start page.

Add a new contact list by user name:

The screenshot shows a screen titled "USER LIST MANAGEMENT". At the top, there are two input fields: "Physical Address" and "User Name". Below these is a keypad with four rows of characters: 0-9, a-j, k-s;, and t-z, -, a left arrow, and a right arrow. At the bottom right are two buttons: "OK" and "Back". Three callout lines are present: line 1 points to the "User Name" field, line 2 points to the "OK" button, and line 3 points to the "Back" button.

Fig. 32 User name

Press the "Add" button to add a new user name. The following functions are available:

No.	Functions
1	Enter the physical address and user name when adding a new contact list. <ul style="list-style-type: none"> - Physical address: the address of an indoor station, from 001 to 250, which is an internal code sent through the bus and identified by all devices within of the system. (Set by using the switches X100,X10,X1 of the indoor station) - User name: Name of a resident.
2	"OK" <ul style="list-style-type: none"> - Press this button to save the settings.
3	"Back" <ul style="list-style-type: none"> - Press this button to return to the start page.

Edit a contact list:

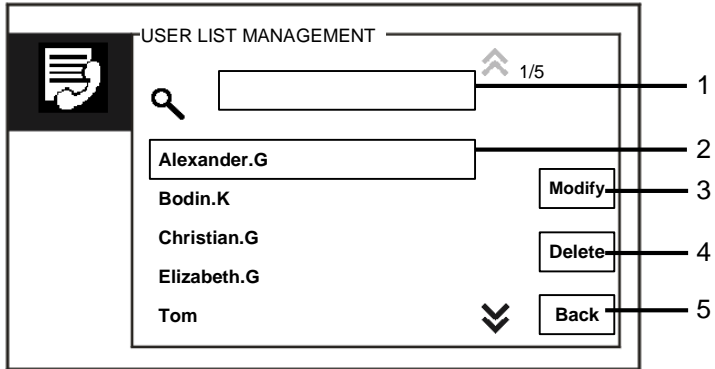

Fig. 33 Editing a user name

Edit the user name. The following functions are available:

No.	Functions
1	Search box - Search for user name by entering a few letters of the first name.
2	User name (list box) - Here, the available user names are listed.
3	"Modify" - Change the specific information of existing user names.
4	"Delete" - Delete a user name by clicking on this button twice.
5	"Back" - Press this button to return to the start page.

Add or edit a new contact list by logic address:

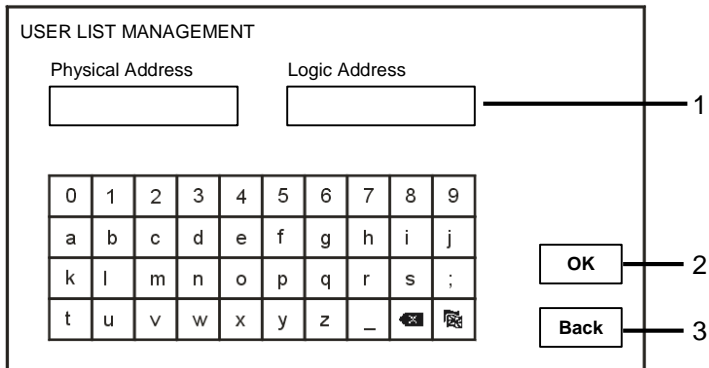

Fig. 34 User list management

Edit or add a logic address. The following functions are available:

No.	Functions
1	Enter the physical address and user logic address when adding a new contact list. <ul style="list-style-type: none"> - Physical address: the address of an indoor station, from 001 to 250, which is an internal code sent through the bus and identified by all devices within the system. (Set by using switches X100,X10,X1 of the indoor station) - Logic address: the code that visitors enter when calling a resident. Usually, the logic address is the apartment No. of a resident which is different from the physical address.
2	"OK" <ul style="list-style-type: none"> - Press this button to save the settings.
3	"Back" <ul style="list-style-type: none"> - Press this button to return to the start page.

4.2.10.4 Call code settings

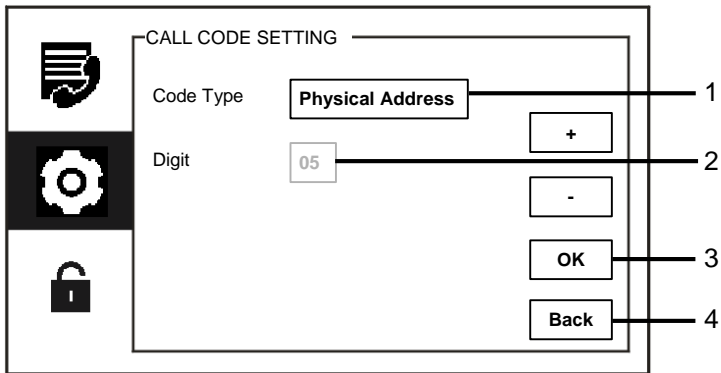

Fig. 35 Call code settings

To the “Call code settings” menu has the following functions:

No.	Functions
1	Code type <ul style="list-style-type: none"> - Change the code type by ticking the box (automatic switchover) or pressing the “Plus / Minus” buttons. - A user can select and click on a physical address to call an indoor station. - A user can select and click on a logic address (The logic address is set in the “user list management” menu).
2	Digit <ul style="list-style-type: none"> - When choosing a logic address, you should set the digits of the logic address by using the “Plus / Minus” buttons. (01-08 digits are available, and the digits of the logic address must be consistent with the ones set in the “user list management” menu)
3	“OK” <ul style="list-style-type: none"> - Press this button to save the settings.
4	“Back” <ul style="list-style-type: none"> - Press this button to return to the start page.

4.2.10.5 Password settings

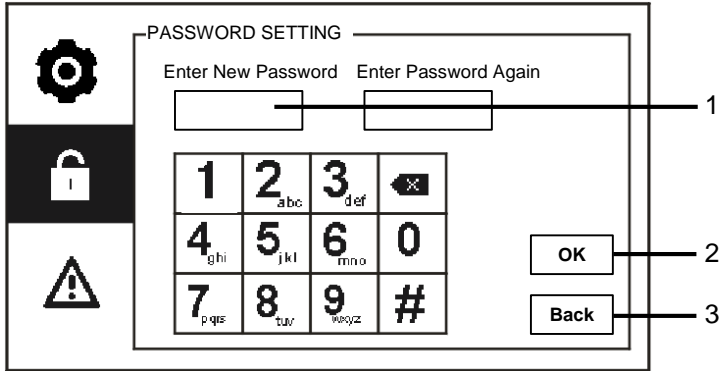

Fig. 36 Password settings

The “Password settings” menu has the following functions:

No.	Functions
1	Enter a new system password. The password must include 6 digits.
2	“OK” - Press this button to save the settings.
3	“Back” - Press this button to return to the start page.

4.2.10.6 Reset factory default

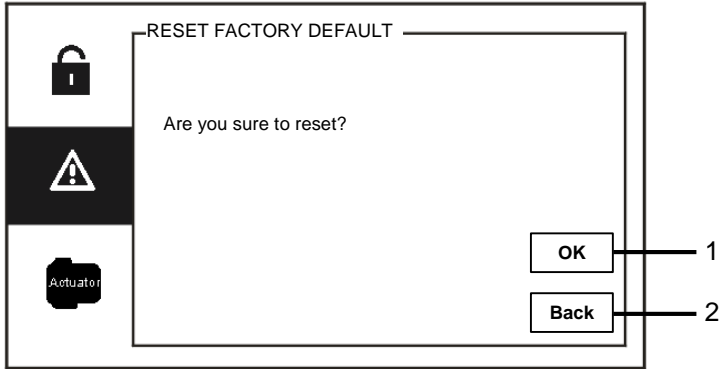

Fig. 37 Resetting factory default

To the “Reset factory default” menu has the following functions:

No.	Functions
1	“OK” - Press this button to save the settings.
2	“Back” - Press this button to return to the start page.

4.2.10.7 Reset Password & Clear All Data

If you forget the system password, you should enter the engineer mode to reset the system password.

Hold "0" while pressing "11411" to enter the engineer mode within 120s when guard unit is powered on.

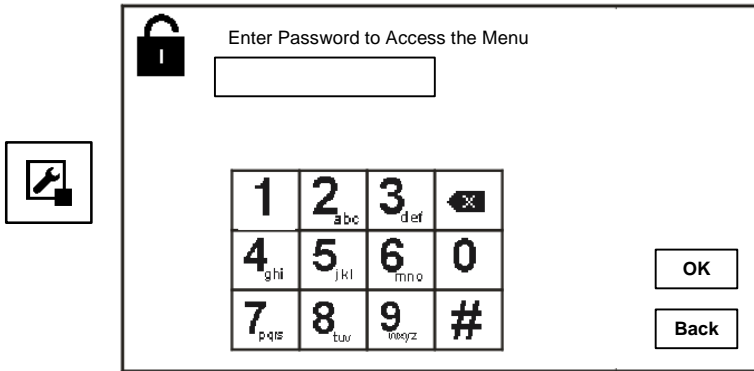

Fig. 38 Resetting password & Clearing all data

In the engineer mode, you can also clear all data in the menu, including the switch actuator lists, user lists, history, etc.

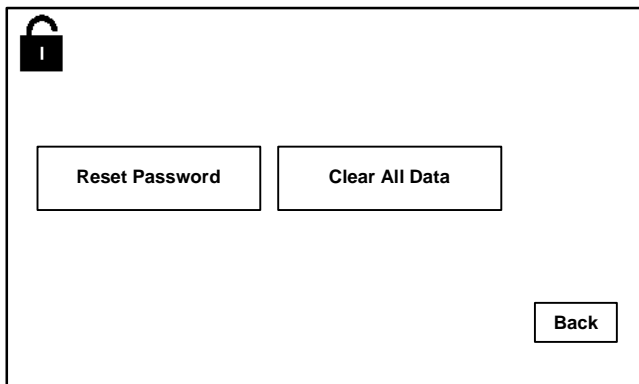

Fig. 39 Resetting password & Clearing all data

4.3 Cleaning



Caution

Risk of damage to the screen surface.

The screen surface can be damaged by hard or sharp objects!
Never use such objects for entries on the touch screen monitor.

- Use your finger or a plastic stylus.

The screen surface can be damaged by cleaning fluids or abrasive agents!

- Clean the surfaces using a soft cloth and commercially available glass cleaner.
- Never use abrasive cleaning agents.

4.4 Adjusting the device

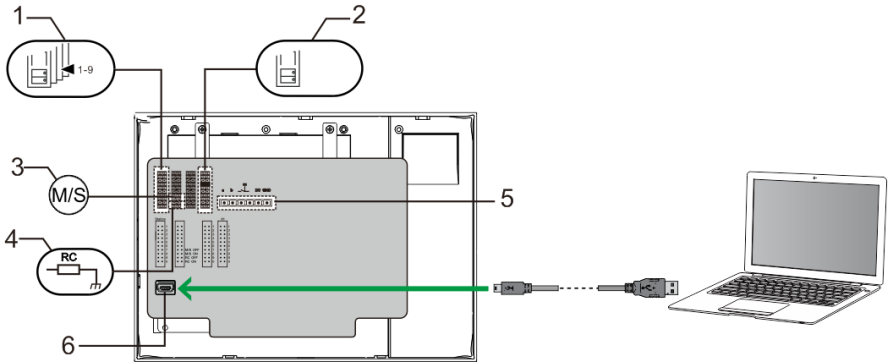

Fig. 40:

1. Station

Jumper to set the address of default outdoor station

2. X1

Jumper to set the address of the guard unit

3. Master /Slave function

Only one guard unit in each building must be set as "Master" (Jumper should be set as 'M/S on'). All other guard units in the same building must be set as "Slave" (Jumper should be set as 'M/S off').

4. Terminal resistor

In video installations or mixed audio and video installations, the Jumper must be set as 'RC on' on the last device of the line.

5. a b = Bus connection

 = Door bell connection

DC GND = Additional power supply

6. USB connector

USB connector for the connection to the PC: download/upload the configuration.
e.g. download the contact lists.

5 Technical data

Designation	Value
Display resolution:	480 x 272
Display size:	4.3"
Operating temperature	-10° C to +55° C
Storage temperature	-40° C – +70° C
Protection	IP 30
Single-wire clamps	2 x 0.28 mm ² – 2 x 0.75 mm ²
Fine-wire clamps	2 x 0.28 mm ² – 2 x 0.75 mm ²
Bus voltage	20-30 V
Size	144 x 198 x 45 mm

6 Mounting / Installation



Warning

Electric voltage!

Risk of death and fire due to electrical voltage of 100-240 V.

- Low-voltage and 100-240 V cables must not be installed together in a flush-mounted socket!

In case of a short-circuit there is the danger of a 100-240 V load on the low-voltage line.

6.1 Requirements for the electrician



Warning

Electric voltage!

Install the device only if you have the necessary electrical engineering knowledge and experience.

- Incorrect installation endangers your life and that of the user of the electrical system.
- Incorrect installation can cause serious damage to property, e.g. due to fire.

The minimum necessary expert knowledge and requirements for the installation are as follows:

- Apply the "five safety rules" (DIN VDE 0105, EN 50110):
 1. Disconnect from power;
 2. Secure against being re-connected;
 3. Ensure there is no voltage;
 4. Connect to earth;
 5. Cover or barricade adjacent live parts.
- Use suitable personal protective clothing.
- Use only suitable tools and measuring devices.
- Check the type supply network (TN system, IT system, TT system) to secure the following power supply conditions (classic connection to ground, protective earthing, necessary additional measures, etc.).

6.2 General installation instructions

- Terminate all branches of the wiring system via a connected bus device (e.g., indoor station, outdoor station, system device).
- Do not install the system controller directly next to the bell transformer and other power supplies (to avoid interference).
- Do not install the wires of the system bus together with 100-240 V wires.
- Do not use common cables for the connecting wires of the door openers and wires of the system bus.
- Avoid bridges between different cable types.
- Use only two wires for the system bus in a four-core or multi-core cable.
- When looping, never install the incoming and outgoing bus inside the same cable.
- Never install the internal and external bus inside the same cable.

6.3 Mounting

Recommended installation height

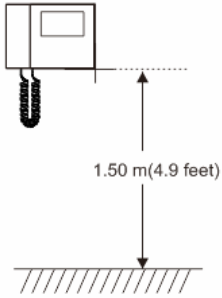

Dismantling

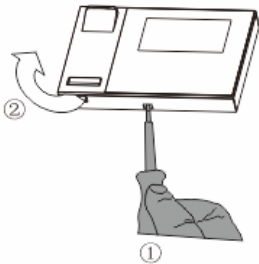

Open the housing panel by pulling the clamp on the bottom of the device.

Installation size

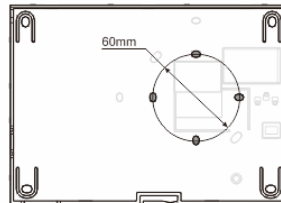
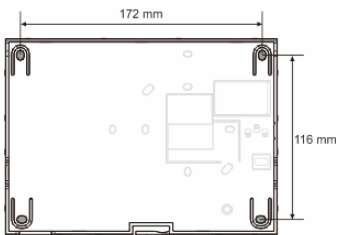

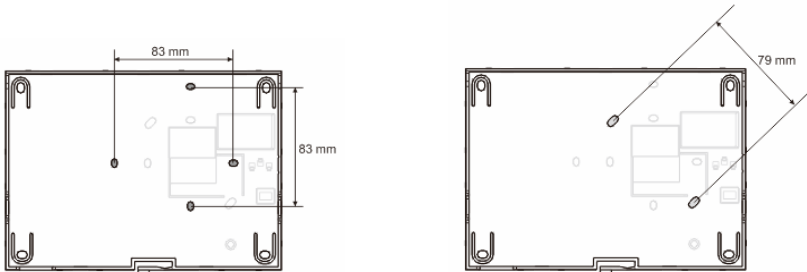

1. The bottom of the device has screw holes and thus can be fastened on the wall according to the above dimension instructions.
2. The bottom of the device can be fixed at the existing flush-mounted box. The size of the compatible flush-mounted box is shown in the above figures.

Wiring

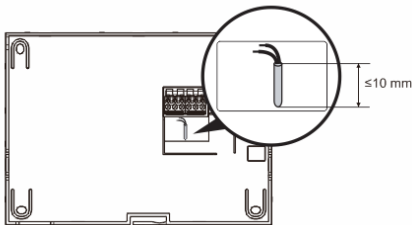

Fix the bottom of the device and connect it with reference to the figures. The insulated section of the cable end must not be longer than 10mm.

Settings

Set the addresses of the preferred outdoor stations and the addresses of the indoor stations on the jumper (see chapter "[Adjusting the device](#)").

Mounted on the wall

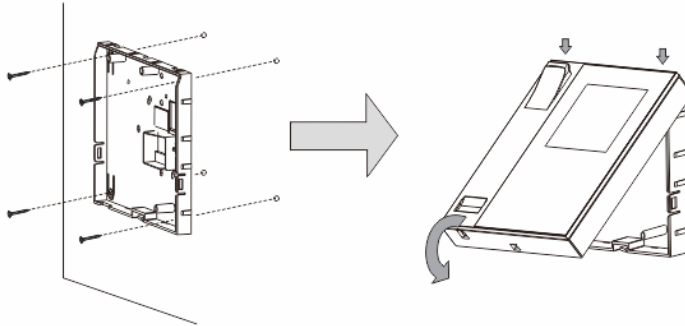

1. Affix the bottom of the device to the wall.
2. Latch the upper part of the device onto its bottom part, place the upper side of the device on the lock-in lugs and then press the bottom side onto the bottom part of the device until it is caught by the clamp,

Mounted with flush-mounted box

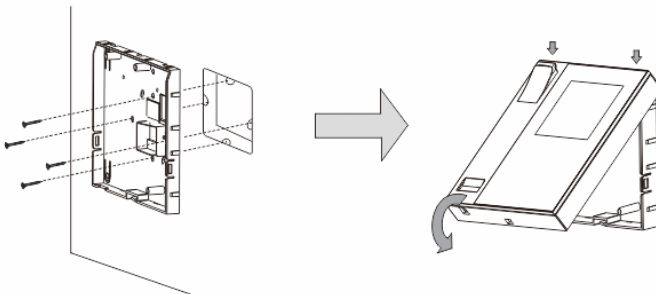

1. Affix the bottom of the device to the existing flush-mounted box.
2. Latch the upper part of the device onto its bottom part: place the upper side of the device on the lock-in lugs and then press the bottom side onto the bottom part of the device until it is caught by the clamp.

Mounted with desktop bracket

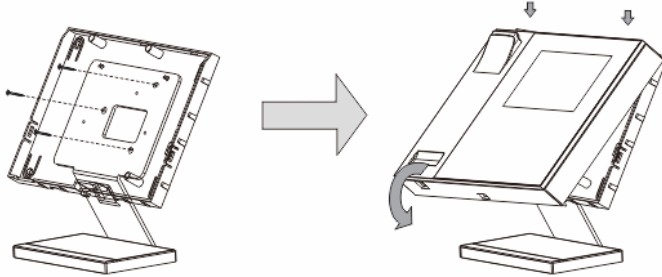

1. Fix the bottom of the device to the desktop bracket.
2. Latch the upper part of the device onto its bottom part: place the upper side of the device on the lock-in lugs and then press the bottom side onto the bottom part of the device until it is caught by the clamp.

The installation of the indoor station is now complete.

ABB-Welcome

Notice

We reserve the right to at all times make technical changes as well as changes to the contents of this document without prior notice.

The detailed specifications agreed to at the time of ordering apply to all orders. ABB accepts no responsibility for possible errors or shortcoming in this document.

We reserve all rights to this document and the topics and illustrations contained therein. The document and its contents, or extracts thereof, must not be reproduced, transmitted or reused by third parties without prior written consent by ABB.